

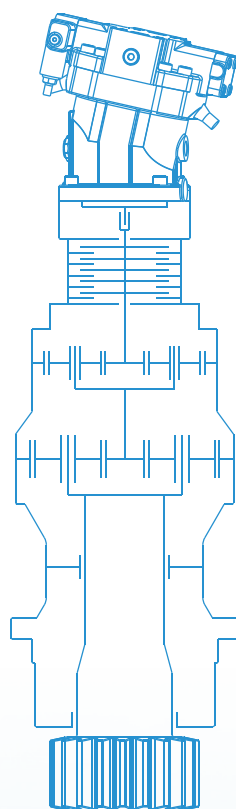

PS Planetary Slewing Gearbox

Modified date 07/2021

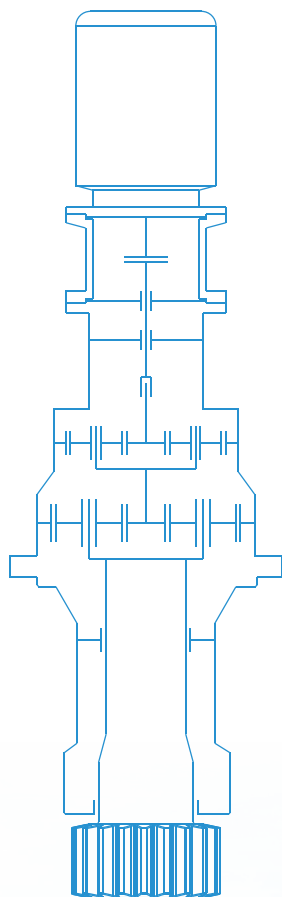

PS Planetary Slewing Gearbox

- » PS planetary slewing gearbox is the ideal drive for the rotation mechanism. Compact structure, good performance. TGE PS planetary slewing gearbox have proved highly successful under extreme bad operating conditions.
 - » Sun and planet wheels material is excellent alloy steel and processed by carburization and quenching. Internal gear wheel material is excellent alloy steel and processed by hardening. All gears grinding.
 - » The connection flange of planet carrier and internal gear wheel are made of ductile graphite iron, and are optimized by computer simulation and stress analysis.
 - » All bearings are from famous brand. The bearings have high loading support and safety.
 - » The input and output are protected with radial skeleton seals, the output standard structure is designed for double seals, in complex and harsh working environment with higher safety and longer service life.
 - » High modular design. Volume production is more economic and speeds up the delivery period.
 - » 2 stage, 3 stage and 4 stage design and wide range of ratio.
 - » Low noise, high efficiency and long operation life.
 - » Easy mounting and maintenance.
-
- » Harbour and dockyard cranes
 - » Shipboard and deck cranes
 - » Offshore cranes
 - » Mobile cranes
 - » Trailers and rescue vehicles
 - » Rotary drilling and crawling cranes
 - » Construction cranes and conveyors
 - » Container gantries
 - » Loading and transshipment cranes
 - » Wind power yaw pitching mechanism





1	Design and Construction	2
2	Type description	3
3	Input modes	3
4	Product explanation	4
5	Type selection explanation	6
6	Transmission capacity	9
7	Outline dimensions	10
8	Mounting method	12
9	Lubrication	13
10	Accessories	13
11	End shaft central hole	14
12	Key and Keyway size	15



1 Design and Construction

PS

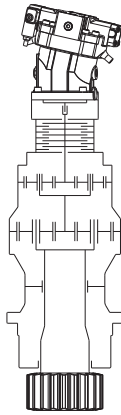
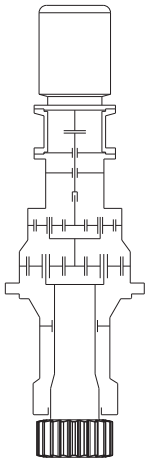

2 stage planetary gearbox

Output torques: 11000 to 150000 Nm
Ratio from 14 to 29
Electric motor/ hydraulic motor drive
Flange A/flange B installation
Input and output in same direction of rotation

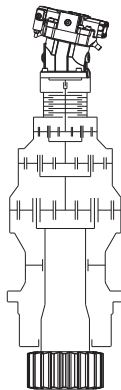
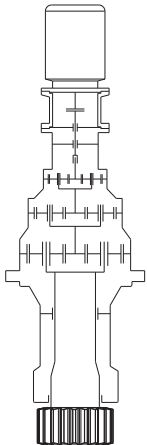

3 stage planetary gearbox

Output torques: 25000 to 230000 Nm
Ratio from 46 to 142
Electric motor/ hydraulic motor drive
Flange A/flange B installation
Input and output in same direction of rotation

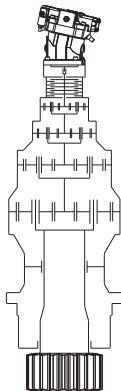
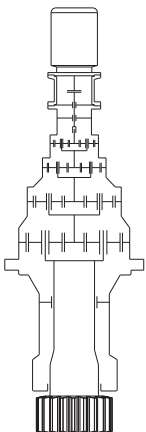

4 stage planetary gearbox

Output torques: 45000 to 590000 Nm
Ratio from 171 to 947
Electric motor/ hydraulic motor drive
Flange A/flange B installation
Input and output in same direction of rotation

Remark: Mechanical efficiency of each stage is 98%, output shaft and the seal rings mechanical efficiency is 99%.
For example: the total mechanical efficiency for 3 stage planetary gearbox $\eta=0.98 \times 0.98 \times 0.98 \times 0.99=0.93$

2 Type Description

	PS	3	27	A	— 106	— H	+ UV32
Series name	PS						
Planetary gear transmit stage	2/3/4 Stage						
Size	27						
Flange mounting form	Flange A Flange B						
Nominal ratio	106						
Input part	H Hydraulic motor input Shaft(motor) input without mark						
Accessories and special requests	UV32						

PS

3 Input Modes

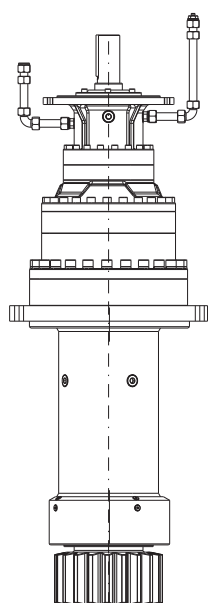

Shaft (motor) input, vertical mounted

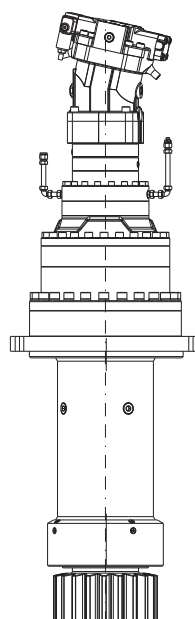
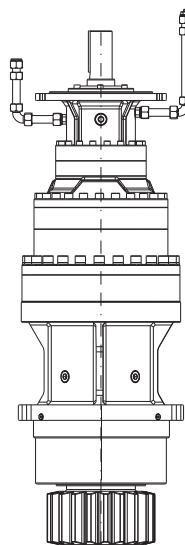

Hydraulic motor input, vertical mounted

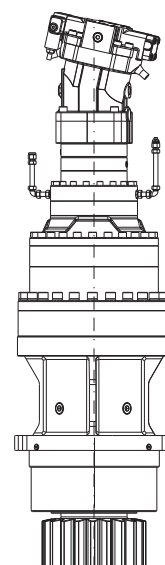

PS with two modular input systems: electric motor input and hydraulic motor input.

(1) When electric motor is input, according to customer's requirements, between motor and gearbox input shaft can fit with ultimate torque limiters/ couplings and operating brake. When the external resistance torque of the slewing section exceeds the permissible torque of the transmission system, the ultimate torque limits the coupling to slip, thus protecting the drive system components from damaging. The working brake is used for deceleration or braking of the slewing mechanism during operation. It can use hydraulic, pneumatic and other braking systems.

(2) When hydraulic motor is input, the input shaft is a DIN 5480 spline shaft, equipped with the hydraulically released spring-action multi-disc brake parking system. This brake safety device is a self contained piston and brake with a minimum release pressure of 15 bar, the maximum pressure is 300 bar. System residual pressure is less than 0.5 bar. The pressure pipe interface is M12X1.5.



4 Product Description

4.1 Eccentricity adjustment

In order to adjust the gap between the output shaft gear and the slewing ring gear accurately, the drive shaft may be eccentric with respect to the output gear shaft and the fixed flange. Flange A installation corresponding mounting hole distribution circle and the spigot eccentricity is $e_1=2.5\text{mm}$, flange B installation corresponding mounting hole distribution circle and the spigot eccentricity is $e_2=1.5\text{mm}$. And the corresponding mounting flange has eccentric high markings for easy identification. As shown in figure 1, figure 2.

PS

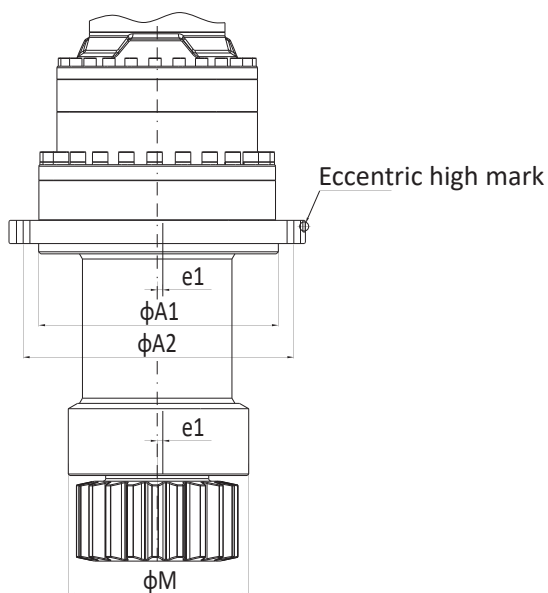

Figure 1

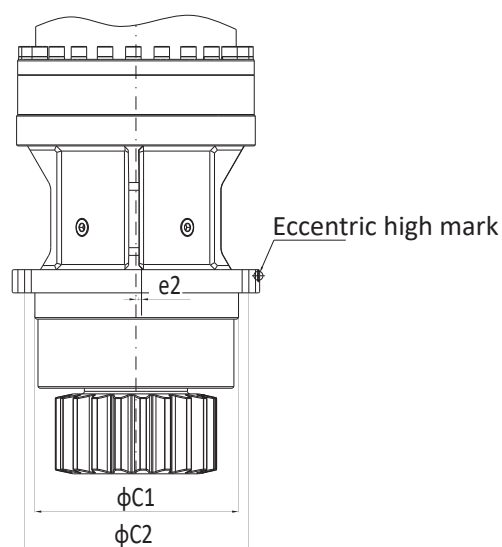
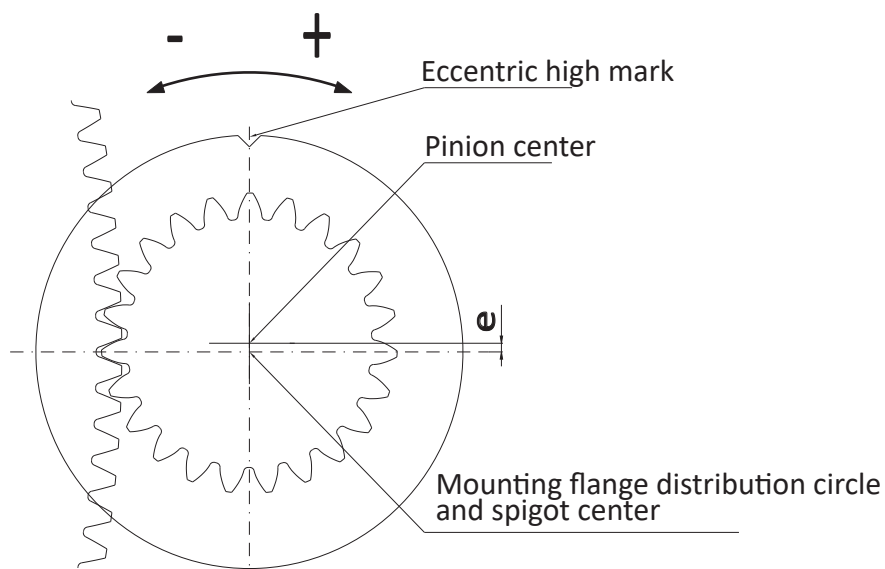

Figure 2



4.2 Output flange slewing shaft length and pinion

4.2.1 Output flange A slewing shaft length can be flexibly designed to meet the mounting dimensions of slewing support;

4.2.2 The output pinion parameters can be designed flexibly, depending on the parameters provided by the customer;

4.2.3 Pinion and slewing output shaft connection methods: DIN 5480 splines, parallel keys and one-piece design.

PS

4.3 Gearbox mounting position instructions

The default mounting position of the gearbox is vertical and the pinion is facing down, if using other mounting positions please declare in advance.

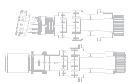

5 Type selection explanation

5.1 Operation instruction

PS planetary gearbox rated dynamic output torques $T_{dyn\ max}$ are based on FEM standards section 1, 3rd edition (FEM-Federation Europeenne de la Manutention). Drive unit group M5, load conditions L2(P=constant, =15rpm), running time classification T5. Ambient temperature +20°C. When the customer calculates the output torques, pay attention to the slewing mechanism accelerates, decelerates, winds and inclines. The maximum torque of the slewing gearbox output gear can only be determined by the exact understanding of the equipment. If the slewing mechanism is classified as other working grades, the output torques must be multiplied by the factor K.

PS

The following parameters must be determined in accordance with FEM 1998 section 1, 3rd edition.

S_{MF} = the maximum moment of inertia produced by friction

S_{MW8} = the maximum torque generated by 80N/m² wind

S_{MS} = the maximum torque generated by the slope

S_{MA} = the maximum torque generated by the accelerate

S_{MW25} = the maximum torque generated by 250N/m² wind

Y_m = Load amplification factor for mechanical group parameters (see FEM-34)

No wind impact of the normal operation

$$S_{Mmax\ I} = (S_{MF} + S_{MA}) Y_m$$

With wind impact of the normal operation

$$S_{Mmax\ II} = (S_{MF} + S_{MA} + S_{MW8}) Y_m$$

$$S_{Mmax\ II} = (S_{MF} + S_{MW25}) Y_m$$

With wind impact and slope of the normal operation

$$S_{Mmax\ II} = (S_{MW8} + S_{MS}) Y_m$$

T_2 : Output torque

T_{2K} : Corrected output torque

K: Application factor (equipment grouping factor)

T_{2K} must $\leq T_{dyn\ max}$ (design torque or sample torque)

5.2 Application factor (running time classification and load conditions)

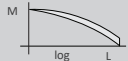
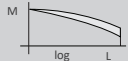
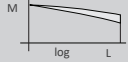
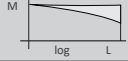
Running time classification	Symbol	T2	T3	T4	T5	T6	T7	T8
	Mean running time per day in hours, related to one year	0.25 to 0.5	0.5 to 1	1 to 2	2 to 4	4 to 8	8 to 16	over 16
	Life in hours 8 years, 200 days/year	400 to 800	800 to 1600	1600 to 3200	3200 to 6300	6300 to 12500	12500 to 25000	25000 to 50000
Load conditions	Collective coefficient K_m	Drive unit class Application factor K						
L1	 to 0.125	M1 0.90	M2 0.90	M3 0.90	M4 0.92	M5 0.92	M6 1.1	M7 1.36
L2	 0.125 to 0.250	M2 0.90	M3 0.92	M4 0.96	M5 1	M6 1.07	M7 1.3	M8 1.6
L3	 0.250 to 0.500	M3 1.05	M4 1.09	M5 1.17	M6 1.23	M7 1.28	M8 1.53	M8 1.89
L4	 0.500 to 1.000	M4 1.32	M5 1.36	M6 1.46	M7 1.53	M8 1.58	M8 1.8	M8 2.22

PS

5.3 Typical load spectrum for crane (figure 3)

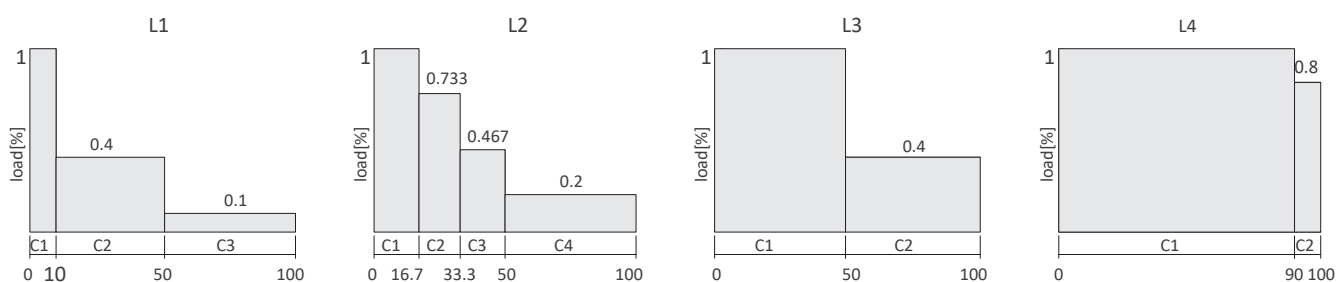

Figure 3 Crane load spectrum



5.3 Classification guidance According FEM section 1, 3rd edition, table T.2.1.3.5

Type of crane(name)	Working accessories	Type of mechanism				
		Hoisting	Slewing	Luffing	Traverse	Travel
Erection crane		M2-M3	M2-M3	M1-M2	M1-M2	M2-M3
Bridge crane	Hook	M5-M6	M4	-	M4-M5	M5-M6
Bridge crane	Grab or magnet	M7-M8	M6	-	M6-M7	M7-M8
Workshop crane	Grab or magnet	M6	M4	-	M4	M5
Crane, Ram crane, Scrap mill crane	Hook or magnet	M8	M6	-	M6-M7	M7-M8
Unloading bridge, Container gantry crane	Hook	M6-M7	M5-M6	M3-M4	M6-M7	M4-M5
Other gantry crane(with crab and/or slewing jib crane)	Grab or magnet	M4-M5	M4-M5	-	M4-M5	M4-M5
Unloading bridge, Container gantry crane(with crab and/or slewing jib crane)	Hook	M8	M5-M6	M3-M4	M7-M8	M4-M5
Shipyards crane, Dock crane, Disassembly crane		M5-M6	M4-M5	M4-M5	M4-M5	M5-M6
Harbor crane(slewing, gantry), floating crane and floating derricks	Hook	M6-M7	M5-M6	M5-M6	-	M3-M4
Harbor crane(slewing, gantry), floating crane and floating derricks	Grab or magnet	M7-M8	M6-M7	M6-M7	-	M4-M5
Floating crane and floating derrick for very heavy loads(usually greater than 100t)		M3-M4	M3-M4	M3-M4	-	-
Deck crane	Hook	M4	M3-M4	M3-M4	M2	M3
Deck crane	Grab or magnet	M5-M6	M3-M4	M3-M4	M4-M5	M3-M4
Tower crane for construction site		M4	M5	M4	M3	M3
Gantry tower		M2-M3	M1-M2	M1-M2	-	-
Railway crane, approved for railway maintenance		M3-M4	M2-M3	M2-M3	-	-
Mobile crane	Hook	M3-M4	M3-M4	M2-M3	-	-

Note: Above are only some typical applications for slewing mechanism

6 Transmission capacity

Nominal ratio	Exact ratio	Type PS	20	22	24	25	26	27	29	31	32	33	34	36
iN	iex	T dynamic N·m	11000	19000	25000	33000	45000	61000	91000	150000	230000	290000	370000	590000
		T static N·m	16500	28500	37500	49500	67500	91500	136500	225000	345000	435000	555000	885000
14	14.11	2 Stage	*	*	*	*	*	*	*	*				
16	16.14		*	*	*	*	*	*	*	*				
19	19.22		*	*	*	*	*	*	*	*				
21	21.45		*	*	*	*	*	*	*	*				
24	24.47		*	*	*	*	*	*	*	*				
29	28.79		*	*	*	*	*	*	*	*				
46	45.97	3 Stage	*	*	*	*	*	*	*	*	*			
53	52.56		*	*	*	*	*	*	*	*	*			
60	60.10		*	*	*	*	*	*	*	*	*			
72	71.57		*	*	*	*	*	*	*	*	*			
80	79.88		*	*	*	*	*	*	*	*	*			
85	85.23		*	*	*	*	*	*	*	*	*			
91	91.13		*	*	*	*	*	*	*	*	*			
106	106.18		*	*	*	*	*	*	*	*	*			
121	121.13		*	*	*	*	*	*	*	*	*			
142	142.49		*	*	*	*	*	*	*	*	*			
171	171.21		*	*	*	*	*	*	*	*	*			
196	195.75		*	*	*	*	*	*	*	*	*	*	*	*
224	223.82	*	*	*	*	*	*	*	*	*	*	*	*	
267	266.53	*	*	*	*	*	*	*	*	*	*	*	*	
278	277.59	*	*	*	*	*	*	*	*	*	*	*	*	
297	297.49	*	*	*	*	*	*	*	*	*	*	*	*	
317	317.39	*	*	*	*	*	*	*	*	*	*	*	*	
339	339.39	*	*	*	*	*	*	*	*	*	*	*	*	
354	354.26	*	*	*	*	*	*	*	*	*	*	*	*	
378	377.95	*	*	*	*	*	*	*	*	*	*	*	*	
399	399.23	*	*	*	*	*	*	*	*	*	*	*	*	
422	421.86	*	*	*	*	*	*	*	*	*	*	*	*	
451	451.10	*	*	*	*	*	*	*	*	*	*	*	*	
481	481.27	*	*	*	*	*	*	*	*	*	*	*	*	
515	514.63	*	*	*	*	*	*	*	*	*	*	*	*	
537	537.18	*	*	*	*	*	*	*	*	*	*	*	*	
566	566.14	*	*	*	*	*	*	*	*	*	*	*	*	
600	599.59	*	*	*	*	*	*	*	*	*	*	*	*	
632	631.91	*	*	*	*	*	*	*	*	*	*	*	*	
684	684.02	*	*	*	*	*	*	*	*	*	*	*	*	
705	705.32	*	*	*	*	*	*	*	*	*	*	*	*	
805	804.65	*	*	*	*	*	*	*	*	*	*	*	*	
848	848.02	*	*	*	*	*	*	*	*	*	*	*	*	
947	946.54	*	*	*	*	*	*	*	*	*	*	*	*	

Note: For transmission ratios not listed, please contact us.

PS



7 Outline dimensions Mounting dimensions

PS

Flange A

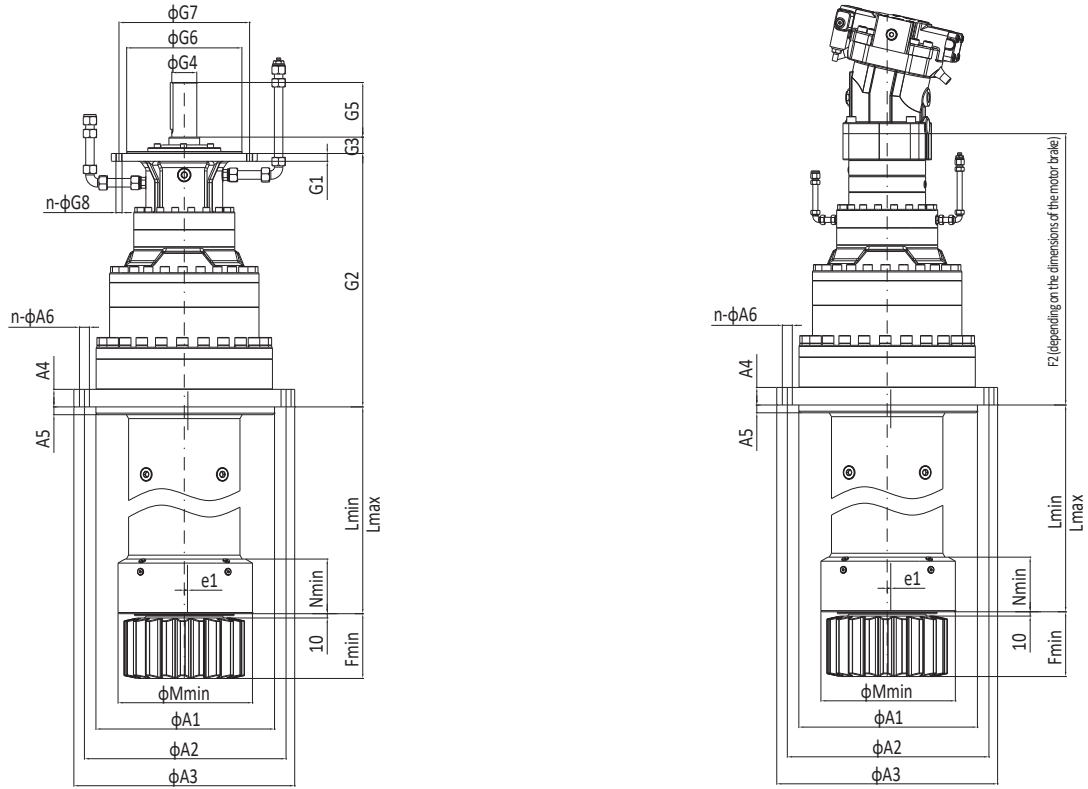

PS	Rated output torque (N.m)		The connecting bolt class of flange A gearbox with frame is 10.9						The connecting bolt class of flange B gearbox with frame is 10.9						Slewing output shaft						
	T _{Dynamic}	T _{Static}	A1	A2 ±0.2	A3	A4	A5	n-A6	C1	C2 ±0.2	C3	C4	C5	n-C6	H1	H2	Lmin	Lmax	Mmin	e1	e2
20	11000	16500	285h7	325	355	25	20	24-φ13.5	230h7	258	282	25	20	24-φ13.5	75	165	230	1300	220h7	2.5	1.5
22	19000	28500	320h7	365	395	30	20	24-φ17.5	255h7	345	375	30	20	24-φ17.5	78	175	250	1300	240h7	2.5	1.5
24	25000	37500	355h7	400	430	30	20	24-φ17.5	280h7	330	368	30	20	24-φ22	100	195	300	1300	270h7	2.5	1.5
25	33000	49500	390h7	440	475	35	20	24-φ22	280h7	395	430	35	20	24-φ22	100	255	330	1300	270h7	2.5	1.5
26	45000	67500	430h7	475	515	40	20	24-φ22	365h7	400	440	35	20	24-φ22	100	260	340	1300	330h7	2.5	1.5
27	61000	91500	465h7	525	575	45	20	24-φ26	395h7	435	480	45	20	24-φ26	185	285	350	1700	340h7	2.5	1.5
29	91000	136500	550h7	600	660	50	30	24-φ26	435h7	485	540	45	30	24-φ33	190	310	420	1700	380h7	2.5	1.5
31	150000	225000	630h7	680	740	50	30	24-φ26								450	1700	400h7	2.5		
32	230000	345000	680h7	750	820	55	30	24-φ33								480	1800	450h7	2.5		
33	290000	435000	790h7	850	920	60	40	30-φ33								500	1800	560h7	2.5		
34	370000	555000	850h7	910	980	70	45	36-φ33								650	1800	585h7	2.5		
36	590000	885000	980h7	1070	1160	70	55	36-φ39								720	1800	700h7	2.5		

- Note: 1) The hydraulic motor input size depends on the hydraulic motor model and the brake selection.
 2) For other dimensions not listed, please contact us.
 3) Flange A slewing shaft length according to customer requirements, weight is for reference only.

Flange B

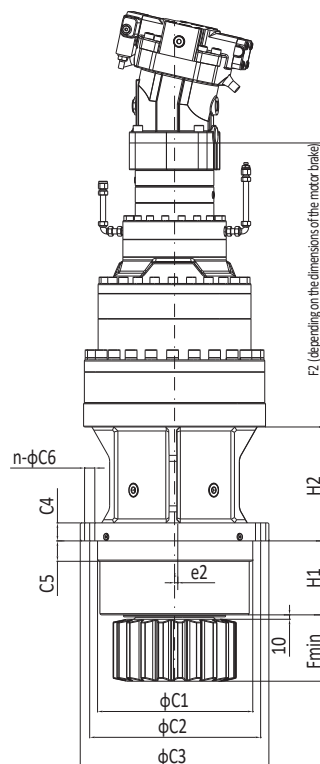
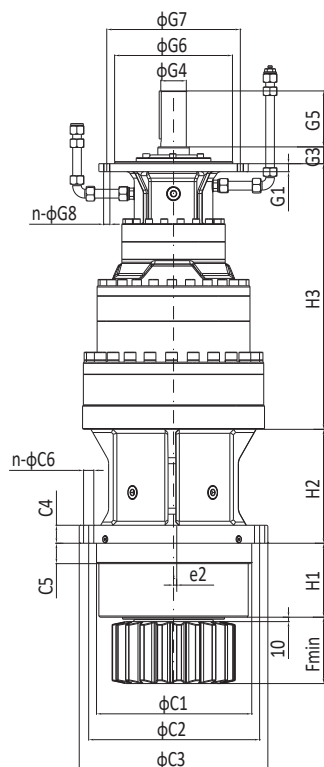

PS

Motor drive																				Weight (Kg)						PS				
2 Stage							3 Stage							4 Stage						2		3		4						
G2	G3	G4	G5	G6	G7 ±0.2	n-G8	H3	G2	G3	G4	G5	G6	G7 ±0.2	n-G8	H3	G2	G3	G4	G5	G6	G7 ±0.2	n-G8	H3	FlangeA	FlangeB	FlangeA	FlangeB	FlangeA	FlangeB	
402	40	65m6	140	300h7	340	8-M16	412	---	---	---	---	---	---	---	---	---	---	---	---	---	---	---	---	207	179	---	---	---	---	20
414	40	65m6	140	300h7	340	8-M16	424	---	---	---	---	---	---	---	---	---	---	---	---	---	---	---	---	254	226	---	---	---	---	22
490	40	75m6	140	360h7	415	8-M16	515	587	40	65m6	140	300h7	340	8-M16	612	---	---	---	---	---	---	---	---	374	337	417	385	---	---	24
503	40	75m6	140	360h7	415	8-M16	518	599	40	65m6	140	300h7	340	8-M16	614	---	---	---	---	---	---	---	---	410	380	498	419	---	---	25
566	40	95m6	170	450h7	500	8-M16	581	637	40	65m6	140	300h7	340	8-M16	652	702	38	55m6	110	250h7	280	8-M16	717	653	563	735	614	809	675	26
579	40	95m6	170	450h7	500	8-M16	594	650	40	65m6	140	300h7	340	8-M16	665	715	38	55m6	110	250h7	280	8-M16	730	742	689	803	764	914	840	27
694	40	120m6	210	550h7	600	8-M16	724	828	40	95m6	170	450h7	500	8-M16	858	899	40	65m6	140	300h7	340	8-M16	929	1214	1102	1395	1284	1446	1334	29
702	40	120m6	210	550h7	600	8-M16	---	836	40	95m6	170	450h7	500	8-M16	---	906	40	65m6	140	300h7	340	8-M16	---	1575	---	1657	---	1707	---	31
								940	40	95m6	170	450h7	500	8-M16	---	1010	40	65m6	140	300h7	340	8-M16	---	---	---	2164	---	2315	---	32
																1234	40	95m6	170	450h7	500	8-M16	---	---	---	---	---	3063	---	33
																1249	40	95m6	170	450h7	500	8-M16	---	---	---	---	---	3705	---	34
																1314	40	95m6	170	450h7	500	8-M16	---	---	---	---	---	5269	---	36



8 Mounting method

The slewing gearbox must be properly mounted on the mechanical support. The mounting center hole of the steel structure must be concentric, and the flange mounting surface must be perpendicular to it. During operation, the relative position of the center hole and the flange should not be affected by the environment and external forces. The manufacturing tolerances of the bracket components and the maximum allowable deformation of the slewing gearbox are shown in the table below.

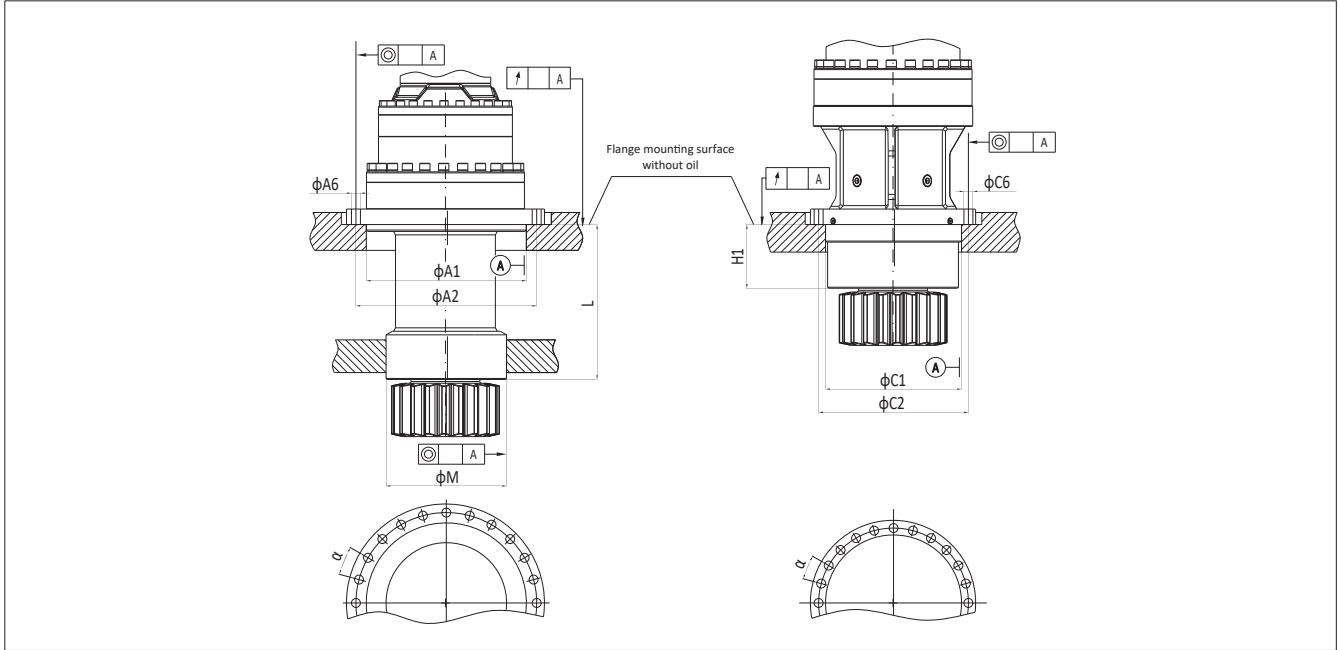

Type	The maximum allowable deformation under the external forces								The center hole must be concentric, allowing maximum machining error					The output shaft of the slewing mechanism is not allowed to be distorted by the function of external force and machining error. The maximum allowable deviation of the central axis is					Type
	A1C1	A2C2±	⊙ A	f A	A6	C6	α±	M	Output shaft length L					Output shaft length L					
PS								200	400	600	800	1000≥	200	400	600	800	1000≥	PS	
20	0.14	0.2	0.3	0.05	13.5	13.5	15'	0.14	0.05	0.10	0.10	0.10	0.15	0.25	0.30	0.30	0.40	0.40	20
22	0.16	0.2	0.3	0.07	17.5	17.5	15'	0.16	0.05	0.10	0.10	0.15	0.20	0.30	0.35	0.35	0.50	0.50	22
24	0.18	0.3	0.5	0.07	17.5	22	10'	0.18	--	0.10	0.10	0.15	0.20	--	0.35	0.35	0.50	0.50	24
25	0.20	0.3	0.5	0.07	22	22	10'	0.20	--	0.10	0.10	0.15	0.20	--	0.35	0.35	0.50	0.50	25
26	0.20	0.3	0.5	0.10	22	22	10'	0.20	--	0.10	0.15	0.20	0.25	--	0.40	0.40	0.60	0.60	26
27	0.23	0.3	0.5	0.10	26	26	10'	0.23	--	0.10	0.15	0.20	0.25	--	0.40	0.50	0.60	0.80	27
29	0.25	0.3	0.5	0.10	26	33	10'	0.25	--	--	0.15	0.20	0.25	--	--	0.50	0.60	0.80	29
31	0.25	0.3	0.5	0.10	26	--	10'	0.25	--	--	0.15	0.20	0.25	--	--	0.50	0.60	0.80	31
32	0.25	0.3	0.5	0.10	33	--	10'	0.25	--	--	0.15	0.20	0.25	--	--	0.50	0.60	0.80	32
33	0.30	0.3	0.6	0.10	33	--	10'	0.30	--	--	0.20	0.25	0.30	--	--	0.60	0.80	0.80	33
34	0.30	0.3	0.6	0.10	33	--	10'	0.30	--	--	0.20	0.25	0.30	--	--	0.60	0.80	0.80	34
36	0.30	0.3	0.6	0.10	39	--	10'	0.30	--	--	0.20	0.25	0.30	--	--	0.60	0.80	0.80	36

The DIN 7184 geometric tolerance standard is defined as:
 The centerline of the workpiece must be in the cylinder with the base line deviation of t=0.2 diameter.
 When the workpiece is rotated around the reference line, the tolerance of the machined surface is not allowed to exceed t=0.2.

9 Lubrication

Lubrication viscosity (heavy industrial gear oil)
[VG320 (code: UV32); VG460 (code: UV46)]

Ambient temperature °C	-20°C - +40°C	+30°C - +50°C
Viscosity	VG320	VG460

Note: 1) All bearings of gearbox are lubricated by oil, except for the end of the output shaft bearings is grease lubrication.
2) Above table viscosity is only for the temperature under 40°C.
3) Ambient temperature below -10°C must use synthetic oil.
4) To make sure the long using life, we suggest to use synthetic oil.
5) If the ambient temperature is not in the range of table, please contact us.

PS

10 Accessories (on request)

- Gearbox
- Hydraulic motor
- Electric motor
- Torque limiter/ torque limit coupling
- Motor mounting flange
- Valve block
- Brake
- Pinion

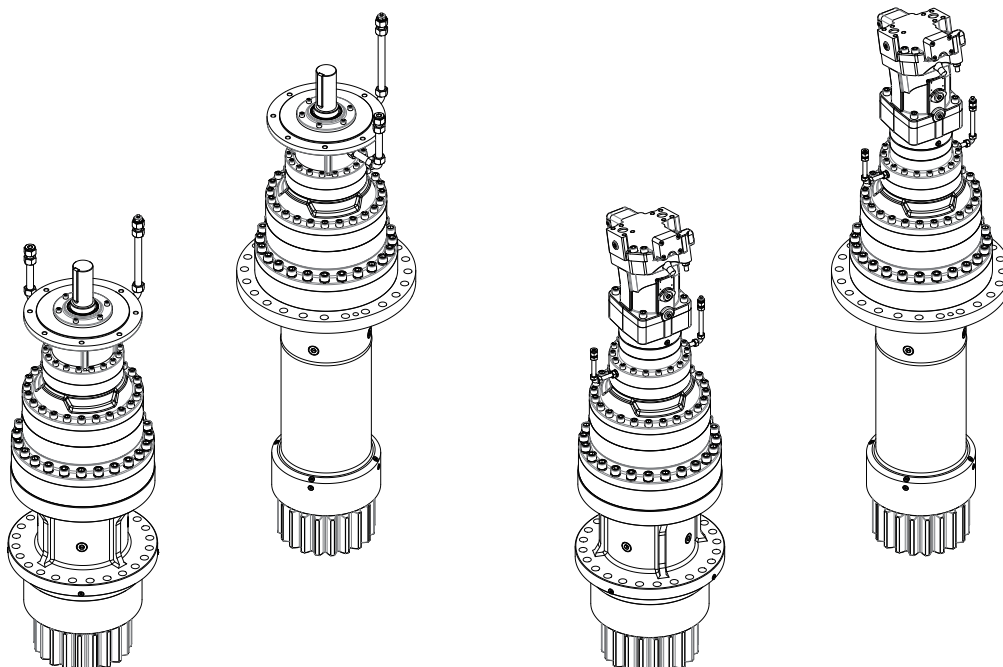



11 End shaft central hole

PS

C type screw central hole

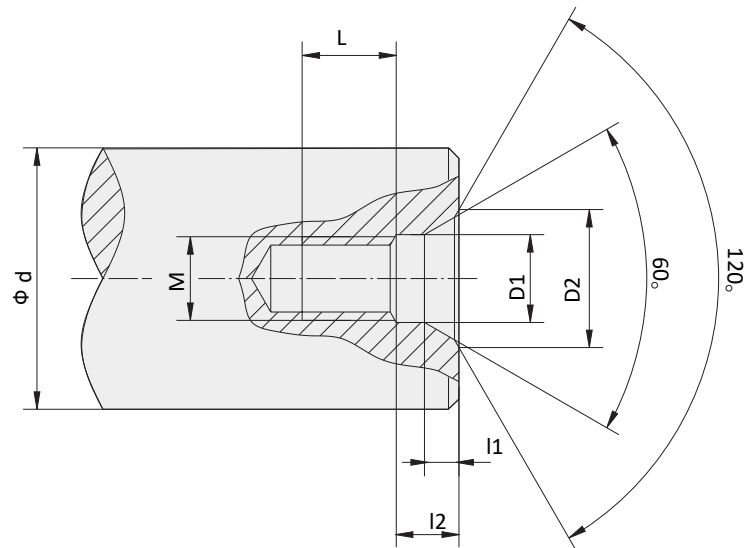

d	M	L	l2	l1	D1	D2
7 < d ≤ 10	M3	10	2.6	1.8	3.2	5.8
10 < d ≤ 13	M4	10	3.2	2.1	4.3	7.4
13 < d ≤ 16	M5	10	4	2.4	5.3	8.8
16 < d ≤ 21	M6	12	5	2.8	6.4	10.5
21 < d ≤ 24	M8	12	6	3.3	8.4	13.2
24 < d ≤ 30	M10	15	7.5	3.8	10.5	16.3
30 < d ≤ 38	M12	20	9.5	4.4	13	19.8
38 < d ≤ 50	M16	25	12	5.2	17	25.3
50 < d ≤ 85	M20	30	15	6.4	21	31.3
85 < d ≤ 130	M24	35	18	8	25	38
130 < d ≤ 225	M30	45	18	11	31	48

12 Key and keyway dimension

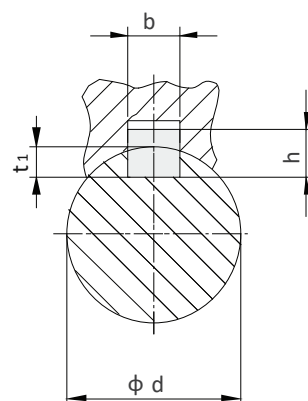
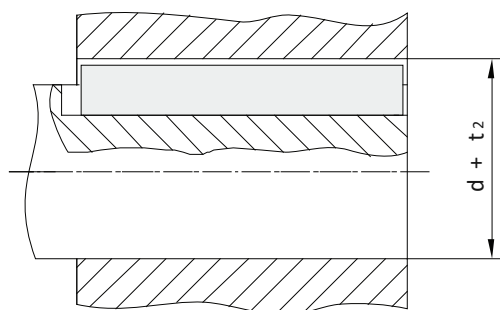

d	b	h	t ₁	d + t ₂
8 < d ≤ 10	3	3	1.8	d + 1.4
10 < d ≤ 12	4	4	2.5	d + 1.8
12 < d ≤ 17	5	5	3	d + 2.3
17 < d ≤ 22	6	6	3.5	d + 2.8
22 < d ≤ 30	8	7	4	d + 3.3
30 < d ≤ 38	10	8	5	d + 3.3
38 < d ≤ 44	12	8	5	d + 3.3
44 < d ≤ 50	14	9	5.5	d + 3.8
50 < d ≤ 58	16	10	6	d + 4.3
58 < d ≤ 65	18	11	7	d + 4.4
65 < d ≤ 75	20	12	7.5	d + 4.9
75 < d ≤ 85	22	14	9	d + 5.4
85 < d ≤ 95	25	14	9	d + 5.4
95 < d ≤ 110	28	16	10	d + 6.4
110 < d ≤ 130	32	18	11	d + 7.4
130 < d ≤ 150	36	20	12	d + 8.4
150 < d ≤ 170	40	22	13	d + 9.4
170 < d ≤ 200	45	25	15	d + 10.4
200 < d ≤ 230	50	28	17	d + 11.4
230 < d ≤ 260	56	32	20	d + 12.4



⚠ You must conform to the following instructions:

- All the construction figures, dimension drawings and other drawings in the catalogue are only the examples, no strict scale defined.(The unmarked dimension units are mm)
The marked weight is only the average value, no binding.
- To avoid the accident, all the rotation components should be covered by customer according to the local safety laws and regulations.
- Read the instruction carefully before operating.
- Fill the lubrication oil before running.
- The oil quantity in the instructions is only for reference. Actual oil filling level should be the same with the mark on oil glass.
- Lubrication oil viscosity is depending on the operating condition and the ambient temperature.
- Only choose the international famous brand lubrication oil.

The functional label of gearbox



Oil glass



Breather



Oil filler



Oil drain





TGE Transmission s.r.o.

9. května 209,
268 01 Hořovice

Technical office Plzeň

Teslova 7b
301 00 Plzeň
info@tge.cz | www.tge.cz

Local dealer

